

EtaPRO® Model-Based Plant Accounting & Settlement System

The Model-Based Plant Accounting & Settlement System is designed and custom configured to fulfill the requirements of the contract between the Plant's Owner/Operator and the Buyer. Depending on the type of plant, each plant's unique contract takes the form of a Power Purchase Agreement (PPA), a Water Purchase Agreement (WPA), or a Power & Water Purchase Agreement (PWPA) combination.

Typically, **PPA/WPA/PWPAs** include charges for:

- Power or Water Capacity,
- Energy and/or Water Output, and
- Fuel or Electricity Demand

These charges are not typical for Solar PV Power Plant PPAs, however. Instead of Capacity and Energy Charges as separate charges, **Solar PV Plant PPAs** typically call for a term called the **Contracted Energy Charge**:

- Contracted Energy Charge
 - Electrical Energy Delivered (Actual)
 - Deemed Electrical Energy Delivered (function of Predicted and Actual)
 - Annual Underperformance Deduction
 - Changes in various fees

This charge includes actual Electrical Energy Delivered (EED) and Deemed Electrical Energy Delivered (DEED) as well as other terms such as changes in fees and an annual Under-Performance Deduction. The DEED is typically a 2nd order regression that predicts the electrical energy that should be delivered as a function of the measured global solar irradiance on plane of array less the actual electrical energy delivered. The annual Under-Performance Deduction calculates a deduction based on the ratio of the Guaranteed to the Actual Performance Ratios.

The EtaPRO® Model-Based PASS Package consists of all utilities necessary to calculate the charges and generate invoices including:

- Interfaces to the plant's DCS/SCADA and Settlement Meter servers
- Data Collection, Monitoring and Conditioning of the data from the plant's servers by the EtaPRO® Server/Client software
- Data Historian, EtaPRO® EPArchive software
- EPreporter® Reports that collect input data from EPArchive® for PASS, FDM and Solar Plant Model Tools
- Fuel Demand Model (FDM) based on EtaPRO®'s thermodynamic VirtualPlant® software
- Online execution of the FDM embedded in the EtaPRO® system
- User Interface for the Offline execution of the FDM using input data from EPreporter® reports
- User Interface for PASS User Manual Inputs
- User Interface for PASS Calculations and Invoice Generation
- Solar Plant Model Actual Performance Ratio Tool
- Solar Plant Model Deemed Energy Coefficients Determination Tool

EtaPRO LLC configures the data flow between the PASS User Manual Inputs and the PASS Calculations and Invoice Generation files using one of two optional methods:

- The PASS User Manual Inputs and the PASS Calculations and Invoice Generation files are directly linked or
- EPRReporter can generate a csv file from the PASS User Manual Input file to be uploaded by the PASS Calculations and Invoice Generation file.

The following data flow diagrams illustrate the second option using csv files.

PASS Data Flow Diagram: Fuel Fired Power Generation Plants

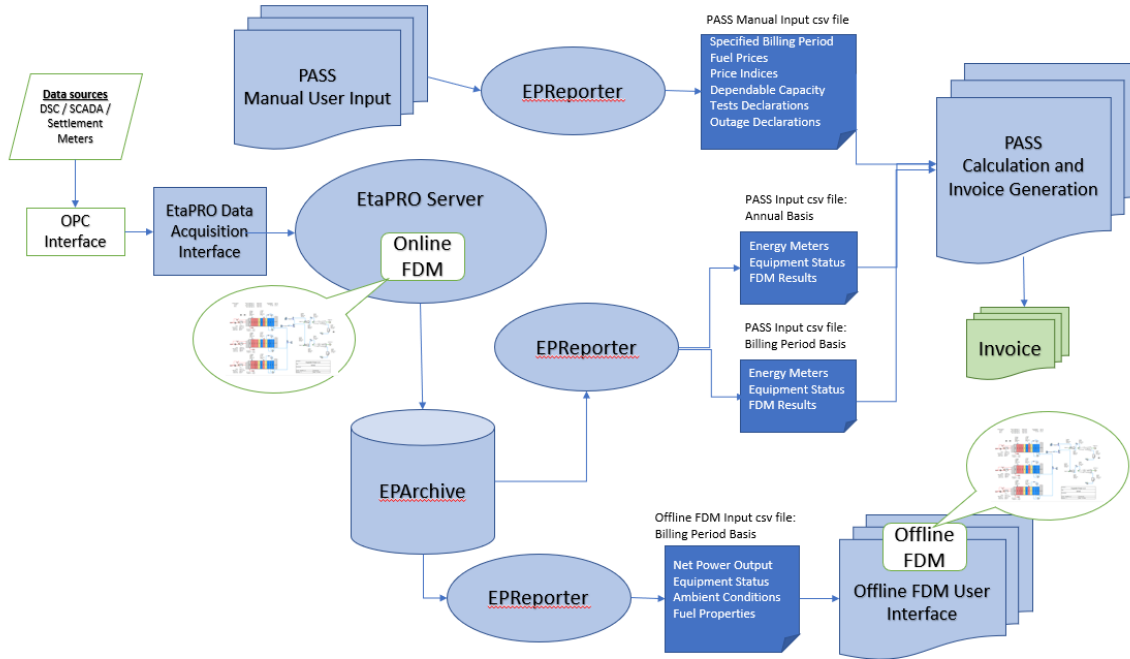

PASS Data Flow Diagram: Solar PV Power Generation Plants

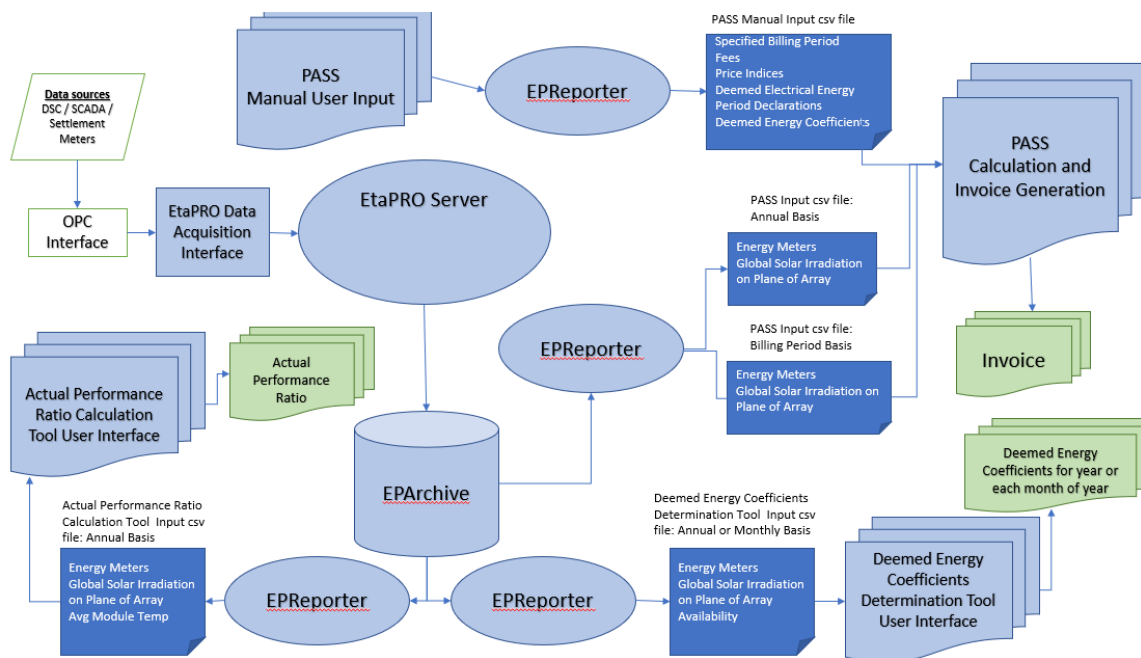

PPA/WPA/PWPA Charges

The **Capacity Charge** is the mechanism by which the Buyer reimburses the Owner for maintaining the power or water output capacity depending on whether the plant generates electrical energy or water as its output. To be reimbursed for capacity, the Owner is responsible for declaring dependable capacities (based on Performance Tests) and outages (values, type (Force Majeure, Scheduled/Planned, Forced, Short Notice, etc.), start times, and end times). Regarding outages, the PPA/WPA may provide different weighting factors for outages occurring in different demand periods (hours of the day, days of the week, public holidays, and periods of the year), whether the outage were forced rather than scheduled and if the outage were a short notice outage.

The **Energy Charge** is the payment from the Buyer for the actual electrical energy delivered under PPA and PWPA contracts. The actual electrical energy delivered is calculated from data collected from commercial energy settlement meters.

Similarly, the **Water Output Charge** or **Water Output Payment** is the payment from the Buyer for the actual water delivered under WPA and PWPA contracts. The actual water delivered is calculated from data collected from commercial water output settlement meters.

For power plants operating under a PPA or PWPA contract that consume fuel to generate power, the **Fuel Charge** is the payment made by the Buyer to reimburse the Owner for the **Fuel Demand** necessary to generate the power. However, the payment is for the **Projected**, rather than actual, **Fuel Demand**. These contracts specify that the **Projected Fuel Demand** is calculated by a **Fuel Demand Model (FDM)**.

Similarly, for Reverse Osmosis (RO) water plants operating under a WPA or PWPA contract that consume electrical energy to desalinate water, the **Electrical Energy Demand Charge**, a component of the **Water Output Payment**, is the payment made by the Buyer to reimburse the Owner for the **Electrical Energy Demand** necessary to generate desalinated water. In some of these contracts, the payment is for the **Actual Electrical Energy Demand**. In other contracts, the payment is for the **Projected**, rather than actual, **Electrical Energy Demand**. These contracts specify that the **Projected Electrical Energy Demand** is calculated by an **Electrical Energy Demand Model (EDM)**. For RO water plants, the EDM is typically a regression or a series of table lookups which EtaPRO LLC will provide as part of the PASS project.

The **Projected Fuel Demand** is calculated by the Fuel Demand Model (FDM). The PPA typically defines the FDM as a design thermodynamic model that is executed using the actual online operating configuration to produce the measured plant net power output. The PPA may also provide for an additional penalty or bonus if the actual fuel demand is greater than (penalty) or less than (bonus) the projected fuel demand by a specified tolerance. Depending on fuel type, the PPA may also define different projected fuel demand calculation methods.

The **Fuel Demand Model (FDM)** is based on EtaPRO's proprietary EtaPRO[®] Performance & Condition Monitoring and VirtualPlant™ Thermodynamic Modeling Framework software and their associated tools, such as the EtaPRO and VirtualPlant add-ins. The FDM uses a steady state thermodynamic mass / energy balance calculations that is customized for your plant. The FDM model, using VirtualPlant, utilizes a sophisticated graphical interface that allows users to build complex plant models, while

offering an intuitive method to rapidly prototype different types of models. This feature is very beneficial if the power plant is modified to improve the performance of the power plant.

The Online FDM is embedded within the EtaPRO™ configuration and is controlled and executed in real time by the EtaPRO™ server. The FDM, as configured in VirtualPlant™ includes major components such as boilers, gas turbine(s), steam turbine(s), HSRG(s), condenser(s), and pump(s). VirtualPlant™ is a generalized thermodynamic modeling framework that operates as a connected system of power plant components, in which the mass and energy balances around each component are satisfied according to the first law of thermodynamics for steady state operation. The diagram below shows the schematic of a typical combined cycle plant.

The inputs to the On-line FDM are determined by actual operations. The EtaPRO server collects and conditions the online data and makes the data available as model inputs for the On-line FDM. The On-line FDM calculates every EtaPRO update cycle (which is configurable and is normally set to once per minute).

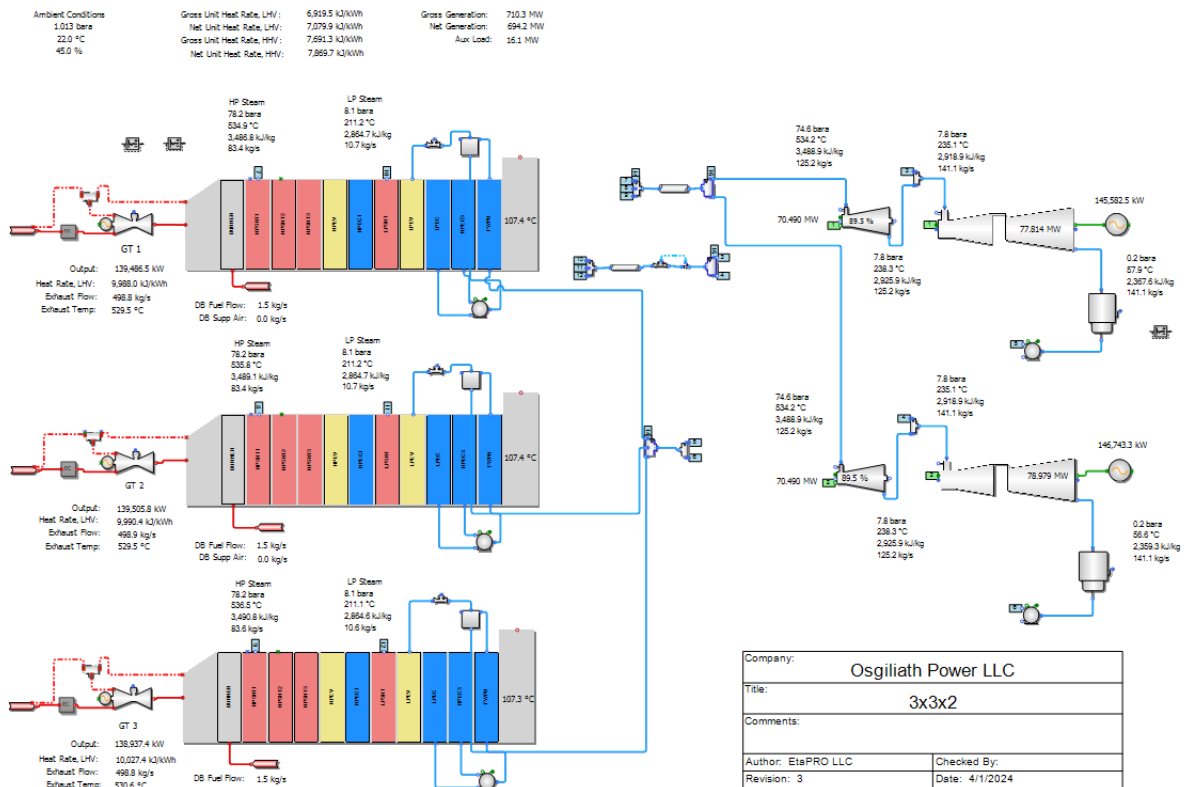

When the water plant is a Multi-Stage Flash Distillation (MSF) process rather than an RO process, a thermodynamic model of the MSF plant will be integrated into the VirtualPlant™ based **Fuel Demand Model**. A typical flowsheet of the integrated process, with the MSF process configured in a subcycle is shown below:

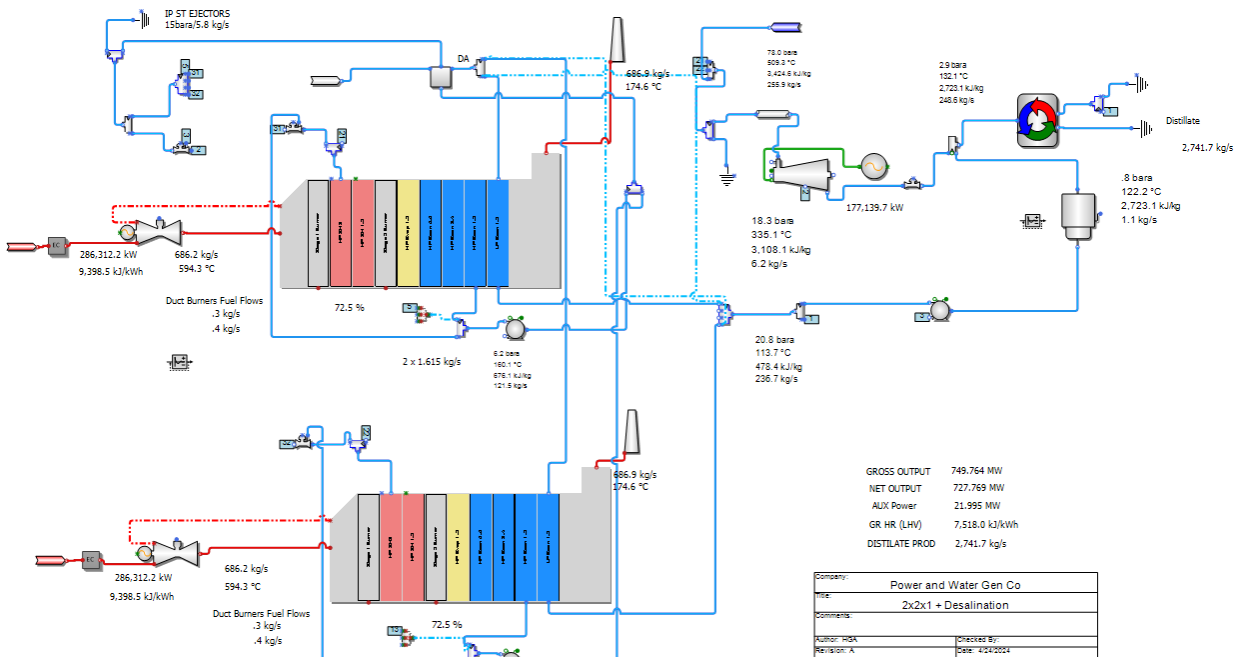

Plant Accounting & Settlement System Package (PASS)

The **Plant Settlement System (PASS)** calculates all terms required by the PPA/WPA to generate an invoice based on all required input data.

Typically, there are three types of input data required for an invoice:

1. PPA/WPA Fixed Values
2. User Manual Inputs / Declarations
3. Online Data

The **PPA/WPA Fixed Values** are typically configured in separate PASS worksheets within the PASS Calculations and Invoice Generation file. They are not hidden in code. Fixed values from the PPA are tabulated and formatted such that they are readily validated against the PPA. These fixed values typically include terms such as:

- Capital Cost Recovery Charge Rates
- Fixed and Variable Operation and Maintenance Charge Rates
- Electrical Energy Variable Operation and Maintenance Charge Rates
- Startup Payments / Deductions
- Period Weighting Factors
- Contracted Specific Net Heat Rate tabulated for each Contract Year
- Contract Years Start Dates

In the PASS files, EtaPRO LLC has configured several features to make validation of data flows within the PASS easy and effective for the user. For example, each of these terms, as well as many other PPA defined terms, are named. Because of that, the user can easily find them within the PASS by using the configured features to locate the term and then the Trace Dependents feature to locate where the term is used throughout the PASS. The following illustrates these features with the Capital Cost Recovery Charge Rate, CCRP:

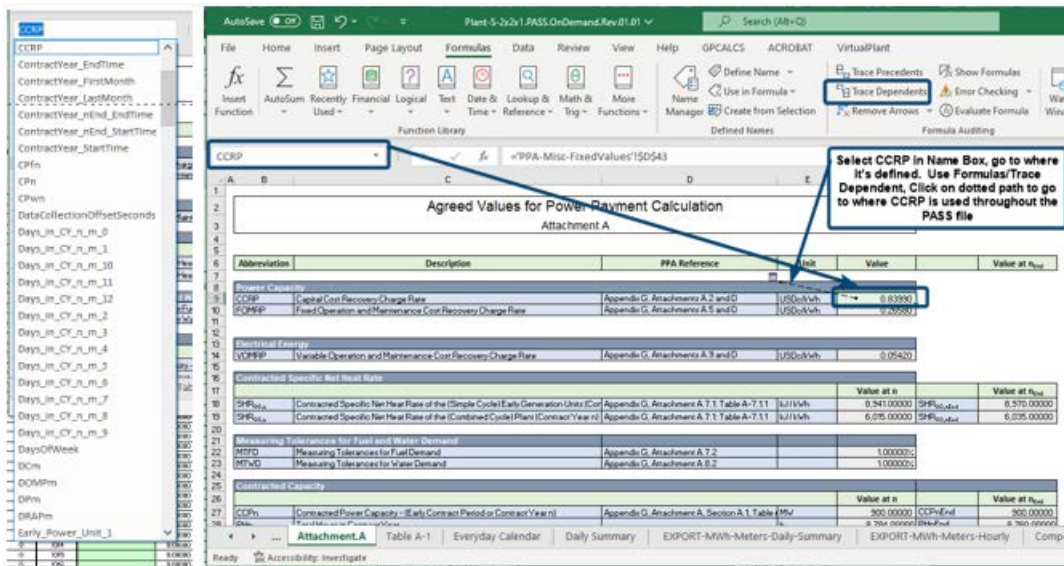

In this example, following Trace Dependents takes the user to any one of the places in which CCRP is used:

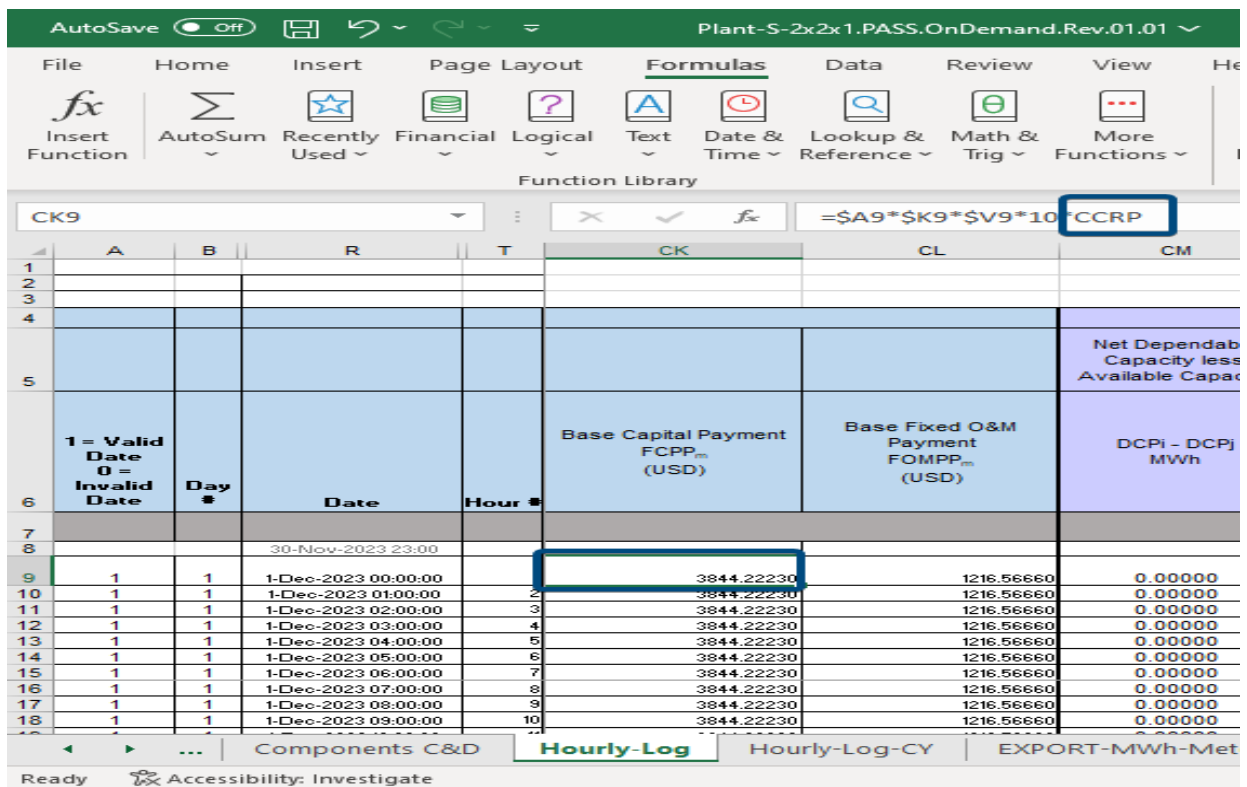

User Manual Inputs and Declarations are entered by the user in the PASS User Manual Inputs file and typically include items such as:

- Commercial Operation Date
- Outage Declarations (values, start time, end time, short notice declaration, type)
- Net Dependable Capacity Tests Declarations (capacity values, start date at which new capacities become valid)
- Fuel prices
- Price indices

As noted earlier, PASS User Manual Inputs file can be either linked with the PASS Calculations and Invoice Generation file or can be hosted in EPreporter. Under the second option, EPreporter will generate a csv file that can then be uploaded into the PASS Calculations and Invoice Generation file.

Online Data are collected from the EPArchive data historian by reports configured in EPreporter using EtaPRO™ Add-ins Data Collection Functions. The live data collections typically include, for each hour (or other interval specified by the PPA/WPA) in the Billing Period and in each Contract Year, plant measurements and Online FDM results such as:

- Energy Settlement Meters Values at Start of each hour for each generator
- Energy Settlement Meters Maximum and Minimum Values in each hour (to check for totalizer meter resets)
- Fuel Settlement Meters Flow Rates
- Fuel Heating Values
- Ambient Conditions (Temperature, Barometric Pressure, Relative Humidity)
- Projected Fuel Demand calculated by the online Fuel Demand Model
- Actual Fuel Demand

PPA/WPA typically include **Annual Reconciliation Calculations** over an entire Contract Year. The PASS will support these annual calculations by collecting data over both the specified Billing Period and the Contract Year. No manual transfers of previous Billing Period calculations are necessary because the PASS automatically calculates all necessary terms for the Contract Year as required for the annual reconciliations.

Invoice Validation

The PASS is designed for easy validation of the invoice by both the Seller and the Buyer. Both the Seller and the Buyer will have copies of the same PASS Invoice Calculation workbook. The Seller generates the input data reports and the invoice for each Billing Period. The Seller can share the input data reports with the Buyer and the Buyer can generate the invoice using the Buyer's copy of the PASS Invoice Calculation workbook. The Seller and Buyer can then confirm that the invoices are identical.

It's important for all parties to be able to easily analyze and investigate how the Total Payment was calculated. The PASS can be used to quickly determine if the Total Payment is accurate and not skewed by an hour or more of bad data from an energy settlement meter, inaccurate fuel price, error in outage declarations or other input errors. The PASS offers the following beneficial features to help the user in these investigations:

- No inputs, fixed values or calculation results are hidden in code. All are visible to the user.
- All input, intermediate, and final calculated terms for the invoice starting from the Billing Period's Total Payment down to the electrical energy or water delivered, net dependable and available capacity, outage declarations, fuel or electrical demand, etc. for each hour (or other

PPA/WPA interval) of the Billing Period are visible and preserved in formatted tables for the user's investigation.

- The PASS Fixed values from the PPA/WPA are tabulated and formatted such that they are readily validated against the PPA/WPA.
- PPA/WPA terms are named in the PASS Invoice Calculation workbook so that the user can use named ranges tools to easily find where and how the term is calculated and drill down to see all values used in the calculation. For example, terms like:
 - Electrical Energy Delivered (EED)
 - Deemed Electrical Energy Delivered (DEED)
 - Guarantee Performance Ratio (GPR)
 - Actual Performance Ratio (APR)
 - Demonstrated Power Capacity (PCDC)
 - Total Projected Fuel Demand (TFDp)
 - Total Projected Water Demand (TWDp)
 - Capital Cost Recovery Charge Rate (CCR, CCRP)
 - Power Capacity Fixed O&M Charge Rate (PCOMR)
 - Consumer and Producer Inflation Multipliers
 - Etc.
- **Settlement Meters** are checked for **Meter Resets** (value at start of hour is less than the value at the start of the previous hour). If a meter reset is detected, the PASS takes that into account when calculating the electrical energy or water output delivered for each hour.
- **Error Trapping** for the **Settlement Meters** includes:
 - if the equipment is online but the meter is not incrementing and
 - if the meter may be out of service due to calibration activities.

If the main (primary) meter for a service is in error, the result from the check (secondary) meter is automatically chosen over the main meter's result. If both are bad for any one interval (hour) the user is alerted in a table that summarizes meter errors.

The PASS is also designed to store all user inputs for the entire Contract Term. This means that all user inputs such as outage declarations, performance tests, public holidays, fuel prices, currency exchange rates, and price indices are entered by the user as they become known. They are then available in the PASS from the beginning of the Contract Term (Commercial Operation Date) through the current Billing Period. Because of this, invoices from earlier Billing Periods can be regenerated at any time by simply entering the Billing Period (month and year). The user would then rerun the data input reports, load the data into the PASS and let it recalculate the invoice for that Billing Period.

PASS user inputs are simplified in that the user must, for outages for example, enter merely the capacity during the outage, the start time and end time for the outage and other outage requirements such as the type of outage and whether it is a short notice outage. Since the settlement system calculations are based on hourly calculations for the Billing Period, the PASS loads the information for the outages into each individual hour (or other PPA/WPA interval) as appropriate for the Billing Period. The PASS then performs all hourly calculations, aggregates the calculations into daily and finally monthly calculations and produces the invoice.

The PASS Calculations and Invoice Generation file loads the declarations from the PASS User Manual Input file into the target hourly intervals.

Shire Power Plant
Declarations of Outages and Deratings:

- Scheduled (Planned and Maintenance) Outages
- Forced Outages
- Planned Deratings (other than Deratings following a Performance Test or Net Dependable Capacity Test)
- Forced Deratings

Outage ID	Outage or Derating		Available
	Start	End	
	Date/Time	Date/Time	User Entered Available Capacity MW
0	1-Jan-2023 00:00	4-Jan-2023 00:01	0.000
1	1-Feb-2023 07:15	1-Feb-2023 10:30	0.000
2	5-Mar-2023 20:00	5-Mar-2023 23:15	0.000
3	10-Mar-2023 08:30	10-Mar-2023 09:45	0.000
4	1-Apr-2023 06:00	1-Apr-2023 09:15	0.000
5	4-Apr-2023 17:00	4-Apr-2023 20:15	0.000
6	1-May-2023 09:00	7-May-2023 12:15	0.000
7	23-Jun-2023 14:00	23-Jun-2023 17:15	0.000
8	20-Jul-2023 08:15	20-Jul-2023 11:30	0.000
9	27-Aug-2023 19:23	27-Aug-2023 22:38	0.000
10	1-Dec-2023 03:15	1-Dec-2023 14:40	0.000
11	9-Dec-2023 20:00	6-Dec-2023 12:00	0.000
12	10-Dec-2023 04:52	10-Dec-2023 07:00	0.000
13	1-Jan-2024 06:00	1-Jan-2024 09:15	600.000
14	4-Jan-2024 17:00	4-Jan-2024 19:45	300.000
15	7-Feb-2024 09:00	7-Feb-2024 16:30	450.000
16	23-Feb-2024 14:00	24-Feb-2024 06:10	500.000
17	20-Mar-2024 08:15	20-Mar-2024 13:50	0.000
18	27-Mar-2024 19:23	28-Mar-2024 03:13	0.000

Date	Hour #	Outage Declared? 0 = No 1 = Yes	Start of Current Declared Outage	End of Current Declared Outage	Fraction of Hour in which Outage is Declared	Weighted Average DC _i	Available Net Dependable Capacity DCP _i
30-Nov-2023 23:00							
1-Dec-2023 00:00:00	1	0	0-Jan-1900 00:00	0-Jan-1900 00:00	0.00000	900.00000	900.00000
1-Dec-2023 01:00:00	2	0	0-Jan-1900 00:00	0-Jan-1900 00:00	0.00000	900.00000	900.00000
1-Dec-2023 02:00:00	3	0	0-Jan-1900 00:00	0-Jan-1900 00:00	0.00000	900.00000	900.00000
1-Dec-2023 03:00:00	4	1	1-Dec-2023 03:15	1-Dec-2023 14:40	0.75000	225.00000	225.00000
1-Dec-2023 04:00:00	5	1	1-Dec-2023 03:15	1-Dec-2023 14:40	1.00000	0.00000	0.00000
1-Dec-2023 05:00:00	6	1	1-Dec-2023 03:15	1-Dec-2023 14:40	1.00000	0.00000	0.00000
1-Dec-2023 06:00:00	7	1	1-Dec-2023 03:15	1-Dec-2023 14:40	1.00000	0.00000	0.00000
1-Dec-2023 07:00:00	8	1	1-Dec-2023 03:15	1-Dec-2023 14:40	1.00000	0.00000	0.00000
1-Dec-2023 08:00:00	9	1	1-Dec-2023 03:15	1-Dec-2023 14:40	1.00000	0.00000	0.00000
1-Dec-2023 09:00:00	10	1	1-Dec-2023 03:15	1-Dec-2023 14:40	1.00000	0.00000	0.00000
1-Dec-2023 10:00:00	11	1	1-Dec-2023 03:15	1-Dec-2023 14:40	1.00000	0.00000	0.00000
1-Dec-2023 11:00:00	12	1	1-Dec-2023 03:15	1-Dec-2023 14:40	1.00000	0.00000	0.00000
1-Dec-2023 12:00:00	13	1	1-Dec-2023 03:15	1-Dec-2023 14:40	1.00000	0.00000	0.00000
1-Dec-2023 13:00:00	14	1	1-Dec-2023 03:15	1-Dec-2023 14:40	1.00000	0.00000	0.00000
1-Dec-2023 14:00:00	15	0	0-Jan-1900 00:00	0-Jan-1900 00:00	0.56857	300.00000	300.00000
1-Dec-2023 15:00:00	16	0	0-Jan-1900 00:00	0-Jan-1900 00:00	0.00000	900.00000	900.00000
1-Dec-2023 16:00:00	17	0	0-Jan-1900 00:00	0-Jan-1900 00:00	0.00000	900.00000	900.00000
1-Dec-2023 17:00:00	18	0	0-Jan-1900 00:00	0-Jan-1900 00:00	0.00000	900.00000	900.00000

All User Declarations are retained in the PASS User Manual Input file from pre-COD through the end of the Contract Term.

Fuel Demand Model Package (FDM)

The FDM module has both online and offline capabilities and is based on EtaPRO's proprietary EtaPRO[®] technologies and VirtualPlant[™] Thermodynamic Modeling Framework software and their associated tools, such as the EtaPRO[™] and VirtualPlant add-ins. The FDM uses a steady state thermodynamic mass / energy balance real-time model that is customized for your plant. The FDM model, using VirtualPlant, utilizes a sophisticated graphical interface that allows users to build complex plant models, while offering an intuitive method to rapidly prototype different types of models. This feature is very beneficial if the power plant is modified to improve its performance.

The **On-line FDM** is embedded within the EtaPRO[™] configuration and is controlled and executed in real time by the EtaPRO[™] server. The FDM, as configured in VirtualPlant[™] includes major components such as boiler(s), gas turbine(s), steam turbine(s), HSRG(s), condenser(s), and pump(s). VirtualPlant is a generalized thermodynamic modeling framework that operates as a connected system of power plant components, in which the mass and energy balances around each component are satisfied according to the first law of thermodynamics for steady state operation.

The inputs to the On-line FDM are determined by actual operations. The EtaPRO server collects and conditions the online data and makes the data available as model inputs for the On-line FDM. The On-line FDM calculates every EtaPRO update cycle (which is configurable and is normally set to once per minute). FDM inputs for a Combined Cycle Power Plant typically include:

- Actual Net Power output
- For the steam turbine, actual operation status (on/off)
- For each gas turbine, actual operation status (on/off)
- For each gas turbine's evaporative cooler, actual operation status (on/off)
- For each HSRG, actual operation status (on/off)
- Actual Ambient Air Temperature
- Actual Ambient Air Humidity
- Actual Barometric Pressure
- Actual Fuel Heating Value
- For each gas turbine, actual power output

- For each gas turbine, actual loading status (baseload/partload)
- For each HRSG's duct burner, actual fuel mass flow

The On-line FDM's calculated results are stored in a hi-speed data historian. The values in the data historian are then available for the Plant Accounting & Settlement System (PASS) as well as for other reporting applications (through EPreporter™). Although the Projected Fuel Demand is the required output from the FDM, the FDM can also provide other calculated results such as:

- Gas turbine fuel consumption,
- Gas turbine and steam turbine power output,
- Auxiliary power consumption,
- HRSG supplementary firing fuel consumption,
- Projected fuel demand for the plant,
- Net heat rate, based on HHV/LHV of the fuel,
- Correction factor for net heat rate based upon the customer's Power Purchase Agreement.

The **Off-line FDM** is a set of parametric studies that uses the same VirtualPlant based FDM that is used for the On-line FDM. An EPreporter report collects all the FDM inputs on an hourly basis (or other interval) from the EPArchive data historian for each hour of the specified Billing Period. The user can then execute the Off-line FDM for each hour of the Billing Period using hourly averages for the FDM inputs.

The input data collected from EPArchive are loaded into one worksheet of the Off-line FDM file:

*Model Input Switches must be integers. Weighted Averages as collected from the Data Archive n integers (based on logic defined by the model user) before the model can use them.

		Equipment Status: Hourly Averages Collected from Data Archives										Equipment Status: Conditioned Values for FDM Inputs						
i = Valid Date 0 = Invalid Date	Date	Hour	Online Status					Fuel Type		Evap Cooler Status			Online Status			Fuel Type		Evap
			GT11 (1=Online)	GT12 (1=Online)	HRSG11 (1=Online)	HRSG12 (1=Online)	ST18 (1=Online)	Gas Turbine Fuel Type	GT11 (1=Online)	GT12 (1=Online)	GT11 (1=Online)	GT12 (1=Online)	HRSG11 (1=Online)	HRSG12 (1=Online)	ST18 (1=Online)	Gas Turbine Fuel Type	GT11 (1=Online)	
			IXJ.A01.A	IXJ.B01.A	HXH.A00.A	HXH.B00.A	IXT.000.A	JXU.A00.A	JXJ.AE0.A	JXJ.BE0.A								
											0.0000	0.0000	0.0000	0.0000	0.0000	0.0000	0.0000	
1	1/1/2024	0:00	1.000	1.000	1.000	1.000	1.000	1	1.000	1.000	1	1	1	1	1	1	1	
1	1/1/2024	1:00	1.000	1.000	1.000	1.000	1.000	0	1.000	1.000	1	1	1	1	1	1	0	
1	1/1/2024	2:00	1.000	1.000	1.000	1.000	1.000	0	0.000	0.000	1	1	1	1	1	1	0	
1	1/1/2024	3:00	1.000	1.000	1.000	1.000	1.000	1	1.000	1.000	1	1	1	1	1	1	1	
1	1/1/2024	4:00	1.000	1.000	1.000	1.000	1.000	0	0.000	0.000	1	1	1	1	1	1	0	
1	1/1/2024	5:00	1.000	1.000	1.000	1.000	1.000	0	1.000	1.000	1	1	1	1	1	1	0	
1	1/1/2024	6:00	1.000	1.000	1.000	1.000	1.000	0	0.000	0.000	1	1	1	1	1	1	0	
1	1/1/2024	7:00	1.000	0.000	1.000	0.000	1.000	0	1.000	1.000	1	0	1	0	1	1	0	
1	1/1/2024	8:00	1.000	0.000	1.000	0.000	1.000	1	1.000	1.000	1	0	1	0	1	1	1	
1	1/1/2024	9:00	1.000	0.000	1.000	0.000	1.000	0	0.000	0.000	1	0	1	0	1	1	0	
1	1/1/2024	10:00	1.000	0.000	1.000	0.000	1.000	0	0.000	0.000	1	0	1	0	1	1	0	
1	1/1/2024	11:00	1.000	1.000	1.000	0.000	1.000	0	1.000	1.000	1	1	1	0	1	1	0	
1	1/1/2024	12:00	1.000	1.000	1.000	0.000	1.000	0	1.000	1.000	1	1	1	0	1	1	0	
1	1/1/2024	13:00	1.000	1.000	1.000	1.000	1.000	0	0.000	0.000	1	1	1	1	1	1	0	
1	1/1/2024	14:00	1.000	1.000	0.000	0.000	0.000	1	1.000	1.000	1	1	0	0	0	1	1	
1	1/1/2024	15:00	1.000	1.000	1.000	1.000	1.000	0	1.000	1.000	1	1	1	1	1	1	0	
1	1/1/2024	16:00	1.000	1.000	1.000	1.000	1.000	0	1.000	1.000	1	1	1	1	1	1	0	
1	1/1/2024	17:00	1.000	1.000	1.000	1.000	1.000	0	1.000	1.000	1	1	1	1	1	1	0	
1	1/1/2024	18:00	1.000	1.000	1.000	1.000	1.000	0	1.000	1.000	1	1	1	1	1	1	0	
1	1/1/2024	19:00	1.000	1.000	1.000	1.000	1.000	0	1.000	1.000	1	1	1	1	1	1	0	

The input values for each case (hourly or some other interval) are then mapped to each parametric study on the worksheet (UserInterface) that executes the Off-line FDM:

Fuel Demand Model								
FDM Inputs		Minimum	Maximum	Input 1	Input 2	Input 3	Input 4	Input 5
Case Number:				1				
Run Switches:		FALSE	TRUE	TRUE	TRUE	TRUE	TRUE	TRUE
Case Name:				HW2024 0.00	HW2024 1.00	HW2024 2.00	HW2024 3.00	HW2024 4.00
Contract Year								
Contract Year:	Contract Year = 1 - 15	1	30	1	1	1	1	1
Ambient Conditions								
Barometric Pressure:	bars	0.92	1.06	1.013	1.03	1.03	1.03	1.03
Temperature:	°C	1	65	60	8	8	8	8
Humidity:	%	0	100	30	80	100	80	80
Fuel								
Fuel Properties								
Fuel Gas LHV:	kJ/kg	25000	50000	43198	43198	43198	43198	431
Fuel Gas (Waste) C/H Ratio:	-	0	4	3.27504	3.27504	3.27504	3.27504	3.275
Fuel Oil LHV:	kJ/kg	25000	45000	42429	42429	42429	42429	424
Fuel Type								
Gas Turbines								
Gas Turbine Fuel Type:	0 = Fuel Gas, 1 = Fuel Oil	0	1	0	0	0	0	1
Equipment Modes								
Gas Turbines								
GT11 On-line:	0 = NO, 1 = YES	0	1	1	1	1	1	1
GT12 On-line:	0 = NO, 1 = YES	0	1	1	1	1	1	1
GT11 Evap. Cooler In Service:	0 = NO, 1 = YES	0	1	1	1	0	1	1
GT12 Evap. Cooler In Service:	0 = NO, 1 = YES	0	1	1	1	0	1	1
Heat Recovery Steam Generators								
HRSG11 On-line:	0 = NO, 1 = YES	0	1	1	1	1	1	1
HRSG12 On-line:	0 = NO, 1 = YES	0	1	1	1	1	1	1
Generator Frequency								
GT11 Generator Frequency:	Hz	48	52	50.00000	50.00000	50.00000	50.00000	50.000
GT12 Generator Frequency:	Hz	48	52	50.00000	50.00000	50.00000	50.00000	50.000

The Off-line FDM results are seen in the same worksheet (UserInterface).